

Universal Cutting

CH75

Compact table-top
Easy to operate



Various tools
for a precious
cutting

Instructions



Operation video

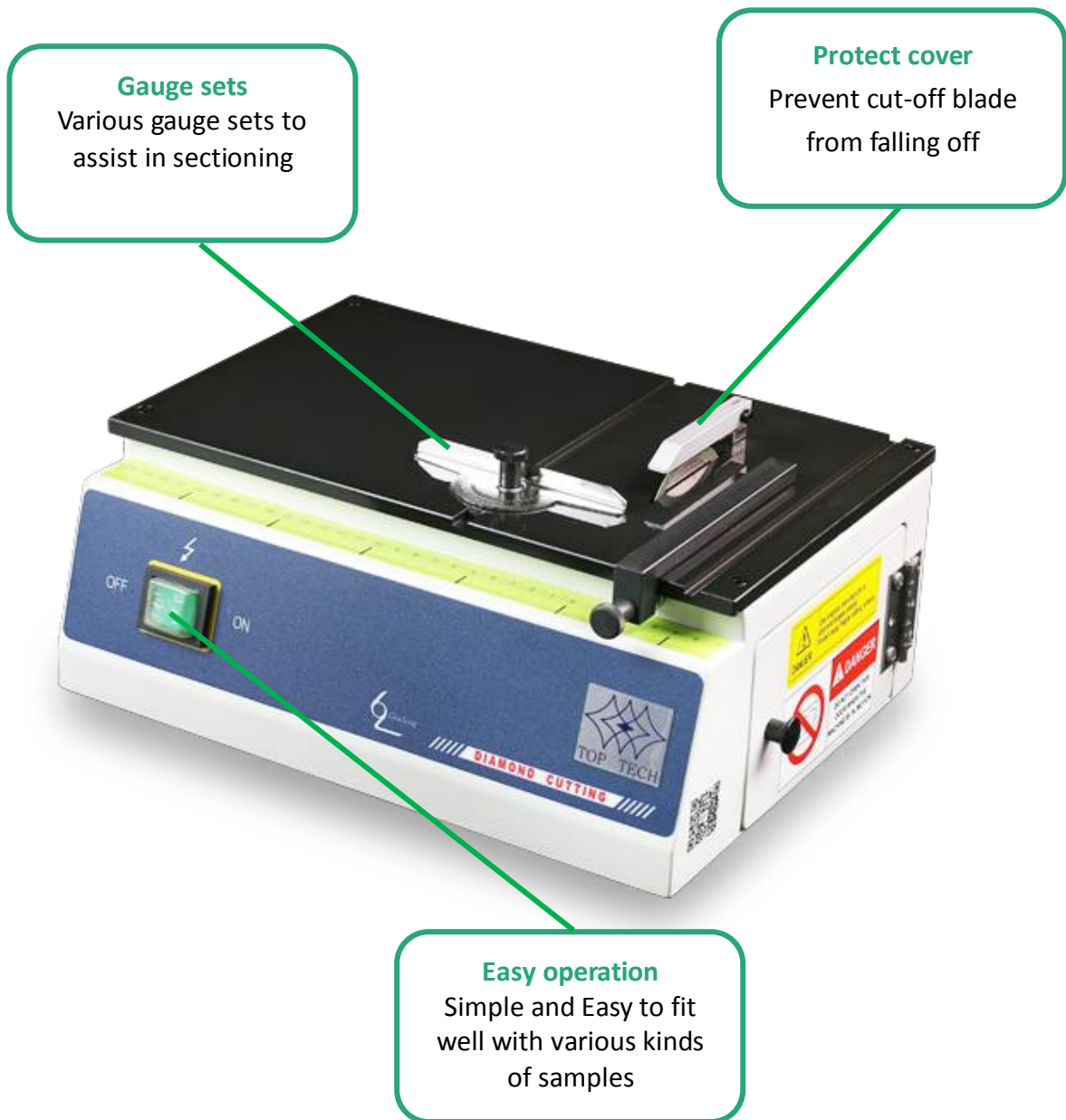

Worthy Options - Working Table



Working Table

Multifunctional working table, it supplies you a place to put your machine and store your accessories. It can be moved easily.

Model No.	TF01	TF02
Size	1000*800*700 mm	1200*1000*700 mm
Sample		

Specifications

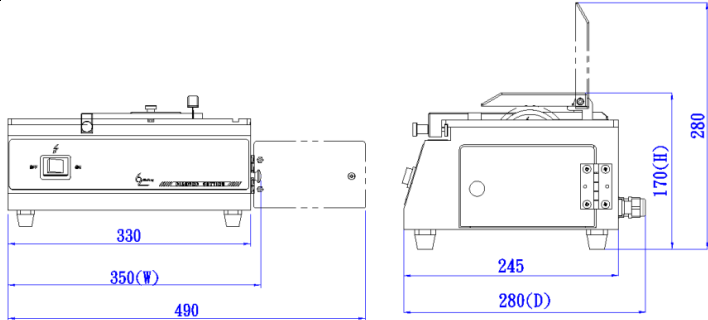
Model No.	CH75
Diamond Wheel	Ø75mm
Table Dimension	320x200mm
Motor Power	150W
Noise Level (idling)	65~76 dB
Max. Section Thickness	2~12 mm (In according to diamond wheel)
Section Table	Appendix 2
Section Method	Dual-shaft section design Angle for section is adjustable
Spindle Rotational Speed	4000 RPM (fixed)
Material Loss of Diamond Wheel	1 ~ 1.5mm (In according to diamond wheel)
Machine Weight	12.5 Kg
Voltage	220VAC 1-phase
Standard Accessories	Electroplating cut off wheel
Machine Dimension	 <p style="text-align: right;">Unit : mm</p>

Appendix 1 –Vise Usage and section table dimension

CH75

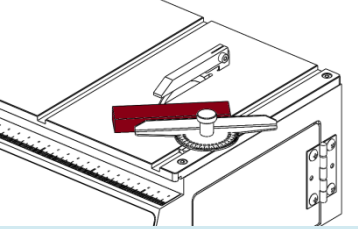
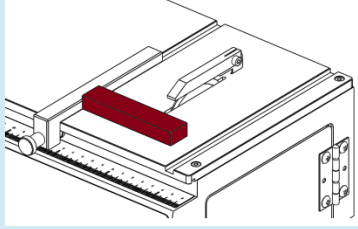
CH7504A Angle gauge set	CH7506A Parallel stand set
	

Cutting Chamber

CH75(unit:mm)

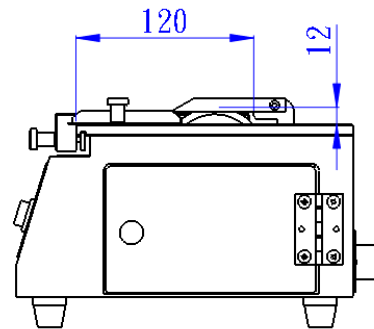
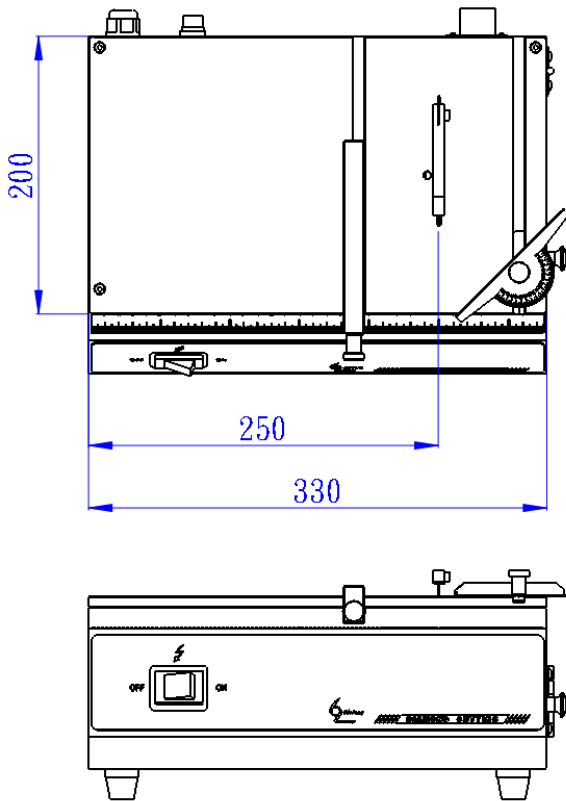

Consumables

Diamond Wheel

Order No.	Materials	Model No.	Diameter* Arbor*Thickness	MOQ	Remark
HW21110107	Mounting sample 、 Resin 、 Plastic sample. Soft gem 、 Quartz 、 Glass 、 Rubber 、 Plastic 、 Asbestos 、 Aluminum 、 Copper 、 FRP 、 PCB Panel	CH75	Ø75xØ11.5x1	10PCS	Segmented rim diamond

Remark: Consumable detail specification show as follow link
<http://toptech.synology.me/Consumables/CuttingEN.pdf>



*Perfect Surface.
Always*



Cutting / Mounting / Grinding & Polishing / Spin Coater

TOP TECH MACHINES CO.,LTD

No.6-3,Siayuan Rd.,Dali,Taichung,412 Taiwan

Tel:886-4-24061658

Fax:886-4-24073200

<http://www.toptech.tw>

<http://toptech.snjapp.com>

Agent



We reserve the right of change design without notice.

NO.A16-01

<http://www.toptech.tw>